

# Uncertainty Reasoning through Similarity in Context

Claudia d'Amato      Nicola Fanizzi

*Dipartimento di Informatica*  
Università degli studi di Bari, *Italy*

2nd ARCOE Workshop @ ECAI2010, *Lisbon, PT*

# Motivation

Reasoning with *Web ontologies*

expressed in standard representations based on *Description Logics*  
difficult due to

- inherent **incompleteness**: OWA vs. CWA
- **incoherence** (+*noise*): heterogeneous and distributed sources

Various solutions investigated in the URSW community,  
e.g modeling **vague** knowledge in terms of *probability* and *fuzziness*:  
support to evolution ?

# Idea

**try inductive methods:**  
often efficient, noise-tolerant and incremental

In particular,

- methods based on **similarity** (or a notion of **distance**) proposed for many reasoning tasks, cast as inductive problems

In the literature: most of the measures for **concept-similarity**

- inductive techniques borrowed from *Machine Learning* require a notion of similarity **between individuals**

# Outline

## Survey of applications of similarity in context

- 1 Preliminaries
- 2 Contextual Metrics for Individuals
  - Similarity in Context
  - Family of Metrics
- 3 Inductive Instance Classification
  - Problem
  - $k$ -Nearest Neighbor Procedure
- 4 Rough DLs
  - Rough Concept Approximations
  - Induced Indiscernibility Relation
  - Extensions
- 5 Conclusions and Outlook

# Preliminaries I

Axioms in terms of a *vocabulary* of

$N_C$  set of **primitive concept** names

$N_R$  set of **primitive role** names

$N_I$  set of **individual** names

and language *constructors*

Semantics defined by **interpretations**  $\mathcal{I} = (\Delta^{\mathcal{I}}, \cdot^{\mathcal{I}})$

where

$\Delta^{\mathcal{I}}$  **domain** of the interpretation (non-empty)

$\cdot^{\mathcal{I}}$  **interpretation function** that maps names to *extensions*  
 each  $A \in N_C$  to a set  $A^{\mathcal{I}} \subseteq \Delta^{\mathcal{I}}$  and  
 each  $R \in N_R$  to  $R^{\mathcal{I}} \subseteq \Delta^{\mathcal{I}} \times \Delta^{\mathcal{I}}$

Then new concepts/roles defined using the language *constructors*

# DL Knowledge Bases

knowledge base  $\mathcal{K} = \langle \mathcal{T}, \mathcal{A} \rangle$

TBox  $\mathcal{T}$  set of axioms  $C \sqsubseteq D$  (resp.  $C \equiv D$ )  
 meaning  $C^{\mathcal{I}} \subseteq D^{\mathcal{I}}$  (resp.  $C^{\mathcal{I}} = D^{\mathcal{I}}$ )  
 where  $C$  is atomic and  $D$  is a concept description

ABox  $\mathcal{A}$  set of assertions — ground axioms  
 e.g.  $C(a)$  and  $R(a, b)$  stating:  
 $a$  belongs to  $C$  and  $(a, b)$  belongs to  $R$

- $\text{Ind}(\mathcal{A})$  = set of individuals occurring in  $\mathcal{A}$

Interpretations of interest (**models**) satisfy all the axioms in  $\mathcal{K}$

- 1 Preliminaries
- 2 Contextual Metrics for Individuals**
  - Similarity in Context
  - Family of Metrics
- 3 Inductive Instance Classification
  - Problem
  - $k$ -Nearest Neighbor Procedure
- 4 Rough DLs
  - Rough Concept Approximations
  - Induced Indiscernibility Relation
  - Extensions
- 5 Conclusions and Outlook

# Context & Similarity I

A **context of reference** must express the essential features for comparing domain objects.

- similarity is not merely a relation between objects but rather between the two in a given context (which is subject to changes) [Goldstone et al., 1997]
- the *task* also matters !

# Context & Similarity II

In the following. . .

## Context

Given a knowledge base  $\mathcal{K}$ ,  
a **context**  $\mathbf{C}$  is a finite set of concept  
descriptions (*features*)

$$\mathbf{C} = \{F_1, F_2, \dots, F_m\}$$

built on concepts and roles defined in  $\mathcal{K}$

# Learning the Context

- given a fitness / criterion function  $J$  for the task
- methods for finding contexts based on *distinguishability* proposed; stochastic search using
  - *Genetic Programming*
  - *Simulated Annealing*

Alternatively, since the metrics are based on weighted projections:

- consider as many features as possible (e.g. all defined concepts)
- find good choice for the weights  $\vec{w}$ 
  - based on **information** (*entropy*)
  - based on **variance**

# A Family of Metrics

Given a context  $\mathbf{C}$  and a weight vector  $\vec{w}$ , the family  $\{d_p^{\mathbf{C}}\}_{p \in \mathbb{N}}$  of functions  $d_p^{\mathbf{C}} : \text{Ind}(\mathcal{A}) \times \text{Ind}(\mathcal{A}) \mapsto [0, 1]$  is defined

$$d_p^{\mathbf{C}}(a, b) = \left[ \sum_{i=1}^m w_i | \pi_i(a) - \pi_i(b) |^p \right]^{1/p}$$

where  $\forall i \in \{1, \dots, m\}$  the  $i$ -th projection function  $\pi_i$ :

$$\pi_i(a) = \begin{cases} 1 & \mathcal{K} \models F_i(a) \\ 0 & \mathcal{K} \models \neg F_i(a) \\ u_i & \text{(prior) otherwise} \end{cases}$$

Inspired by *Minkowski's* norms; can be proven to be semi-distances

- 1 Preliminaries
- 2 Contextual Metrics for Individuals
  - Similarity in Context
  - Family of Metrics
- 3 Inductive Instance Classification**
  - Problem
  - ***k***-Nearest Neighbor Procedure
- 4 Rough DLs
  - Rough Concept Approximations
  - Induced Indiscernibility Relation
  - Extensions
- 5 Conclusions and Outlook

# Inductive Classification

Instance checking as a

## Learning Problem

given a query concept  $Q$  and  
a query individual  $x_q$

using  $S_Q$  sample of prototype training instances  
with correct membership values

$$h_Q(x_i) = v \in \{-1, 0, +1\} = V$$

determine  $\hat{h}_Q(x_q)$

i.e. *estimate* membership of  $x_q$  w.r.t.  $Q$

We use well known non-parametric methods:

- $k$ -NN, Parzen Windows                      no ind. model, only rel. distances
- RBF Nets, SVMs ...                              build an inductive model

# $k$ -Nearest Neighbor Procedure I

A sort of **analogical reasoning** [d'Amato et al.,2008-URSW I]

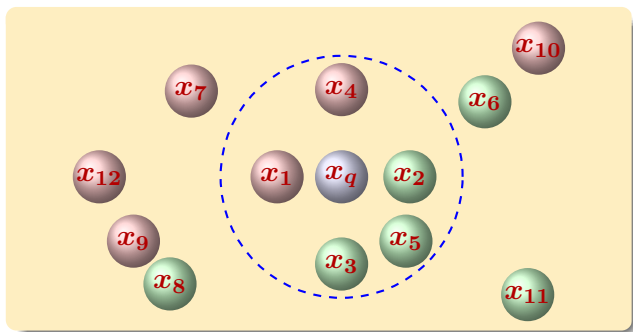

Selection of the  $k = 5$  nearest neighbors.  
green=positive ex., red=negative ex.

# $k$ -Nearest Neighbor Procedure II

Weighted majority vote:

given  $NN_k(x_q) = \{x_1, \dots, x_k\}$  of  $x_q$ 's nearest neighbors w.r.t.  $d_p^C$ , the estimate of the membership hypothesis is

$$\hat{h}_Q(x_q) = \operatorname{argmax}_{v \in V} \sum_{i=1}^k \overbrace{\gamma(d_p^C(x_i, x_q))}^{\text{proximity weight}} \cdot \overbrace{\delta(v, h(x_i))}^{\text{vote}}$$

where:

$\delta$  Kronecker indicator function

$\gamma$  decaying function

e.g.  $\gamma(x) = (1 - x)^b$  or  $\gamma(x) = 1/x^b$  for some  $b > 0$

# Lessons Learned

Applying this and similar methods based on density estimates (RBF Networks, SVMs, ...)

- build the inductive model *once* and classify **efficiently** *many times*
- may give an answer in case of **uncertain** class-membership (can be forced to do that)
- may provide an estimate of the **likelihood** of the answer
- experimentally: **nearly** sound and complete (few omission errors)
- measure used also in **unsupervised** tasks:  
e.g. *clustering* individual resources

- 1 Preliminaries
- 2 Contextual Metrics for Individuals
  - Similarity in Context
  - Family of Metrics
- 3 Inductive Instance Classification
  - Problem
  - $k$ -Nearest Neighbor Procedure
- 4 **Rough DLs**
  - **Rough Concept Approximations**
  - **Induced Indiscernibility Relation**
  - **Extensions**
- 5 Conclusions and Outlook

# Rough DL

Recently **Rough DLs** introduced [Schlobach et al.,IJCAI2007] as a mechanism for modeling *vague* concepts by means of a *crisp* specification of its approximations

## Approximations

Given an indiscernibility relation  $R$ ,  
the **upper approximation** of a concept  $C$  is

$$\overline{C} = \{a \mid \exists b : R(a, b) \wedge b \in C\} \quad (\text{typical instances})$$

the **lower approximation** is

$$\underline{C} = \{a \mid \forall b : R(a, b) \rightarrow b \in C\} \quad (\text{prototypical instances})$$

If  $R$  expressed in terms of the knowledge base  
then standard reasoners can be used

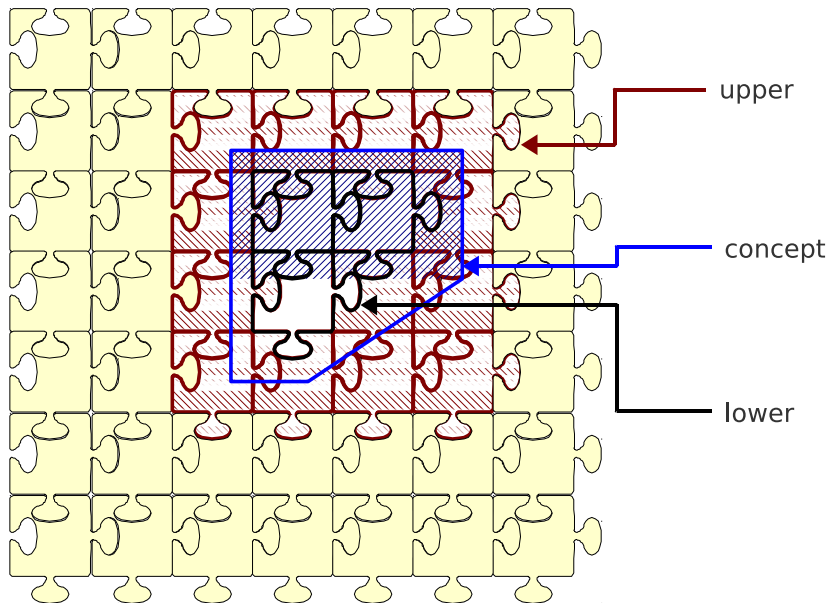

# Induced Indiscernibility Relation I

**Idea** induce an equivalence relation based on context

[Fanizzi et al., URSW2008]

Given a context **C** and the related projection functions  $\pi_i$   
two individuals **a** and **b** are **indiscernible** w.r.t. **C** iff

$$\forall i \in \{1, \dots, m\}: \pi_i(a) = \pi_i(b)$$

Indiscernibility relation  $R_C$  induced by **C** defined:

$$R_C = \{(a, b) \in N_I \times N_I \mid \forall i \in \{1, \dots, m\}: \pi_i(a) = \pi_i(b)\}$$

# Induced Indiscernibility Relation II

$R$  partitions  $N_I$  in equivalence classes.

given a generic individual  $a$ , the *induced concept* is  $C_a = [a]_C$

Extension of a **C-definable** concept corresponds to a combination (union) of equivalence classes.

Other concept descriptions, say  $D$ , may be approximated **contextual upper** and **lower approximations** of  $D$  w.r.t.  $C$ , defined:

$$\overline{D}^C = \{a \in N_I \mid C_a \sqcap D \neq \perp\}$$

$$\underline{D}_C = \{a \in N_I \mid C_a \sqsubseteq D\}$$

# Extensions I

Using a notion of tolerance [Doherty et al.,2003]:

## Definition (tolerance)

A tolerance function on a set  $U$  is a function  $\tau : U \times U \mapsto [0, 1]$  such that  $\forall a, b \in U$

- (1)  $\tau(a, a) = 1$  and
- (2)  $\tau(a, b) = \tau(b, a)$

Given  $\tau$  on  $U$  and a threshold  $\theta \in [0, 1]$ , a neighborhood function  $\nu_\theta : U \mapsto 2^U$  is

$$\nu_\theta(a) = \{b \in U \mid \tau(a, b) \geq \theta\}$$

a.k.a. the  $\theta$ -neighborhood of  $a$

# Extensions II

Consider  $N_I = U$  and a metric  $d_p^C$ .

Equivalence relationships  $R_C^\theta$  on  $N_I$  can be defined, with classes made up of individuals within a degree of similarity, controlled by  $\theta$ :

$$[a]_C = \nu_\theta(a)$$

Upper and lower approximation w.r.t.  $R_C^\theta$  descend straightforwardly

- 1 Preliminaries
- 2 Contextual Metrics for Individuals
  - Similarity in Context
  - Family of Metrics
- 3 Inductive Instance Classification
  - Problem
  - $k$ -Nearest Neighbor Procedure
- 4 Rough DLs
  - Rough Concept Approximations
  - Induced Indiscernibility Relation
  - Extensions
- 5 Conclusions and Outlook

# Contribution and Outlook

An operative notion of similarity in context for reasoning with ontologies

Two applications:

- 1 inductive instance classification
- 2 Vague concept modeling (+reasoning) in Rough-DL

instance-based: naturally evolve

## Ongoing / Future Work

- **kernel methods** based on similar settings
- **ranking** answers w.r.t. likelihood measure
- **unsupervised** tasks. outlier and novelty detection, clustering

# time for questions

## Offline

- Claudia d'Amato      `claudia.damato@di.uniba.it`
- Nicola Fanizzi      `fanizzi@di.uniba.it`